

**SPEC. NO.:** PS-51153-xxxxx-xxx

**REVISION:** A

**PRODUCT NAME:** 0.635 mm PITCH SMT S/T D/R TYPE CONNECTOR

**PRODUCT NO:** 51153series; 51152 series;

PREPARED:	CHECKED:	APPROVED:
DATE: <b>2018/09/06</b>	DATE: <b>2018/09/06</b>	DATE: <b>2018/09/06</b>

TITLE: 0.635mm Board To Board CONN

RELEASE DATE: 2017/07/04

REVISION: 0

ECN No: ECN-1801372

PAGE: **2** OF **8**

1	REVISION HISTORY .....	3
2	SCOPE .....	4
3	APPLICABLE DOCUMENTS.....	4
4	REQUIREMENTS.....	4
5	PERFORMANCE .....	5
6	INFRARED REFLOW CONDITION .....	7
7	CONNECTOR USAGE .....	8
8	PRODUCT QUALIFICATION AND TEST SEQUENCE.....	9

Aces P/N: **51153 series**

TITLE: 0.635mm Board To Board CONN

RELEASE DATE: 2017/07/04

REVISION: O

ECN No: ECN-1801372

PAGE: **3** OF **8**

### 1 Revision History

Rev.	ECN #	Revision Description	Approved	Date
O	ECN-1801372	NEW SPEC	SHI, YANAN	2017/07/04
A	ECN-1811254	Update Salt Spray	SHI, YANAN	2018/11/12

TITLE: 0.635mm Board To Board CONN

RELEASE DATE: 2017/07/04

REVISION: 0

ECN No: ECN-1801372

PAGE: **4** OF **8**

## 2 SCOPE

This specification covers performance, tests and quality requirements for **0.635mm pitch BOARD TO BOARD CONNECTOR**.

Aces's P/N : 51153-xxxxx-xxx series, 51152-xxxxxx-xxx series;

## 3 APPLICABLE DOCUMENTS

**EIA-364** ELECTRONICS INDUSTRIES ASSOCIATION

## 4 REQUIREMENTS

### 4.1 Design and Construction

- 4.1.1 Product shall be of design, construction and physical dimensions specified on applicable product drawing.
- 4.1.2 All materials conform to R.o.H.S. and the standard depends on TQ-WI-140101.

### 4.2 Materials and Finish

- 4.2.1 Contact: High performance copper alloy (**Phosphor Bronze**)  
Finish: (a) Contact Area: **Refer to the drawing**  
(b) Under plate: **Refer to the drawing**  
(c) Solder area: **Refer to the drawing**
- 4.2.2 Housing: Thermoplastic or Thermoplastic High Temp., UL94V-0

### 4.3 Ratings

- 4.3.1 Working Voltage Less than **36 Volts AC (per pin)**
- 4.3.2 Voltage: **100 Volts AC (per pin)**
- 4.3.3 Current: **0.5 Amperes**
- 4.3.4 Operating Temperature : **-55°C to +85°C**

TITLE: 0.635mm Board To Board CONN

RELEASE DATE: 2017/07/04

REVISION: 0

ECN No: ECN-1801372

PAGE: 5 OF 8

**5 Performance**

## 5.1. Test Requirements and Procedures Summary

Item	Requirement	Standard
Examination of Product	Product shall meet requirements of applicable product drawing and specification.	Visual, dimensional and functional per applicable quality inspection plan.
<b>ELECTRICAL</b>		
Item	Requirement	Standard
Low-signal Level Contact Resistance	40 m $\Omega$ Max.(initial)per contact $\Delta R$ 20 m $\Omega$ Max.	Mate connectors, measure by dry circuit, 20mV Max., 10mA Max. (EIA-364-23)
Insulation Resistance	500 M $\Omega$ Min.	Unmated connectors, apply 250 V DC between adjacent terminals. (EIA-364-21)
Dielectric Withstanding Voltage	250 VAC Min. at sea level for 1 minute. No discharge, flashover or breakdown. Current leakage: 1 mA max.	Test between adjacent contacts of unmated connectors. (EIA-364-20)
Temperature rise	30°C Max. Change allowed	Mate connector: measure the temperature rise at rated current after:0.5 A/Power contact. The temperature rise above ambient shall not exceed 30°C The ambient condition is still air at 25°C (EIA-364-70 METHOD 2)
<b>MECHANICAL</b>		
Durability	50 cycles.	The sample should be mounted in the tester and fully mated and unmated the number of cycles specified at the rate of 25.4 $\pm$ 3mm/min. (EIA-364-09)
Mating / Unmating Forces	Mating Force: 70 gf Max/CTK. Unmating Force: 12 gf Min/CTK	Operation Speed : 25.4 $\pm$ 3 mm/minute.. Measure the force required to mate/Unmate connector. (EIA-364-13)
Terminal / Housing Retention Force	0.20kgf MIN.	Apply axial pull out force at the speed rate of 25.4 $\pm$ 3 mm/minute. On the terminal assembled in the housing.
Fitting Nail /Housing Retention Force	0.20kgf MIN.	Apply axial pull out force at the speed rate of 25.4 $\pm$ 3 mm/minute. On the fitting nail assembled in the housing.

TITLE: 0.635mm Board To Board CONN

RELEASE DATE: 2017/07/04

REVISION: O

ECN No: ECN-1801372

PAGE: **6** OF **8**

Vibration	1 $\mu$ s Max.	The electrical load condition shall be 100 mA maximum for all contacts. Subject to a simple harmonic motion having amplitude of 0.76mm (1.52mm maximum total excursion) in frequency between the limits of <b>10 and 55 Hz</b> . The entire frequency range, from <b>10 to 55 Hz</b> and return to <b>10 Hz</b> , shall be traversed in approximately 1 minute. This motion shall be applied for 2 hours in each of three mutually perpendicular directions. (EIA-364-28 Condition I)
Shock (Mechanical)	1 $\mu$ s Max.	Subject mated connectors to <b>50 G's</b> (peak value) <b>half-sine</b> shock pulses of <b>11</b> milliseconds duration. Three shocks in each direction shall be applied along the three mutually perpendicular axes of the test specimen (18 shocks). The electrical load condition shall be 100mA maximum for all contacts. (EIA-364-27, test condition A)

### ENVIRONMENTAL

Item	Requirement	Standard
Resistance to <b>Reflow</b> Soldering Heat	See Product Qualification and Test Sequence Group 9 ( <b>Lead Free</b> )	Pre Heat : 150°C~180°C, 60~120sec. Heat : 230°C Min., 40sec Min. Peak Temp. : 260°C Max, 10sec Max. <b>Reflow number cycle: 2 times</b> (EIA-364-56)
Heat Resistance	See Product Qualification and Test Sequence Group 4	Subject mated connectors to temperature life at <b>105°C</b> for <b>96 hours</b> . Measure Signal. (EIA-364-17, Test condition A)
Thermal Shock	See Product Qualification and Test Sequence Group 3	Mate module and subject to follow condition for 5 cycles. 1 cycles: -55 +0/-3 °C, 30 minutes +85 +3/-0 °C, 30 minutes (EIA-364-32, test condition I)
Humidity	See Product Qualification and Test Sequence Group 3	Mated Connector 60°C, 90~95% RH, 96 hours. (EIA-364-31, Condition A, Method II)

TITLE: 0.635mm Board To Board CONN

RELEASE DATE: 2017/07/04

REVISION: 0

ECN No: ECN-1801372

PAGE: 7 OF 8

Temperature life	See Product Qualification and Test Sequence Group 5	Subject mated connectors to temperature life at <b>85°C</b> for <b>96 hours</b> . Measure Signal. (EIA-364-17, Test condition A)
Salt Spray (Only For Gold Plating)	See Product Qualification and Test Sequence Group 6	Subject mated/unmated connectors to <b>5% salt-solution concentration, 35°C</b> (I) Gold flash for 8 hours (II) Gold plating 3 u" for 48 hours. (II) Gold plating 5 u"(Min) for 96 hours. (EIA-364-26)
Solder ability	Tin plating: Solder able area shall have minimum of 95% solder coverage. Gold plating: Solder able area shall have minimum of 95% solder coverage	And then into solder bath, Temperature at <b>245 ±5°C</b> , for <b>4-5 sec</b> . (EIA-364-52)
Hand Soldering Temperature Resistance	Appearance: No damage	T ≥ 350°C, 3sec at least.
SO2 Gas	Appearance: No damage 40 m Ω Max. (initial)per contact ΔR 20 m Ω Max.	Subject mated connectors : Gas Concentration:SO2=50+/-5ppm Temperature:40+/-2°C Duration:24 hours

**Note.** Flowing Mixed Gas shall be conduct by customer request.

## 6 INFRARED REFLOW CONDITION

### 6.1. Lead-free Process

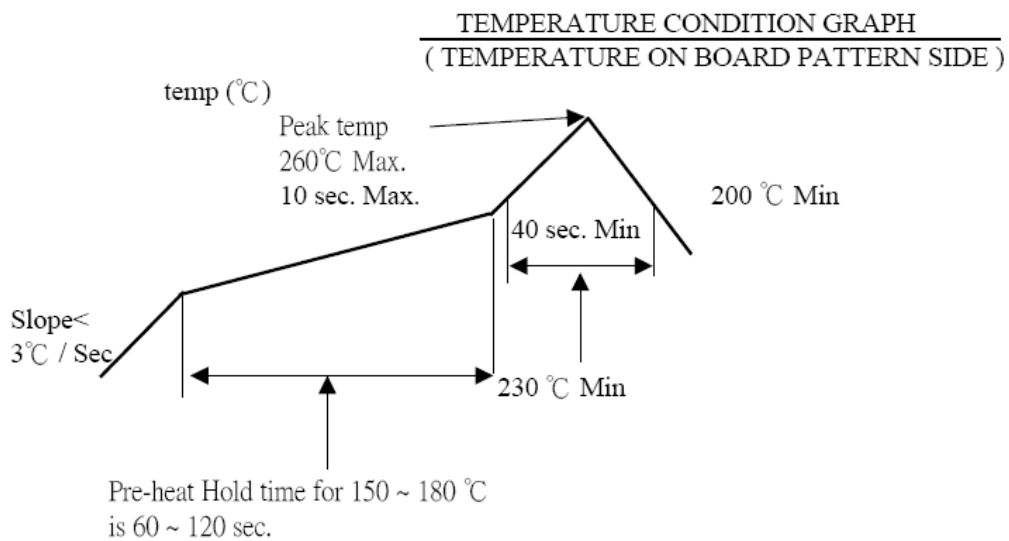

## 7 CONNECTOR USAGE

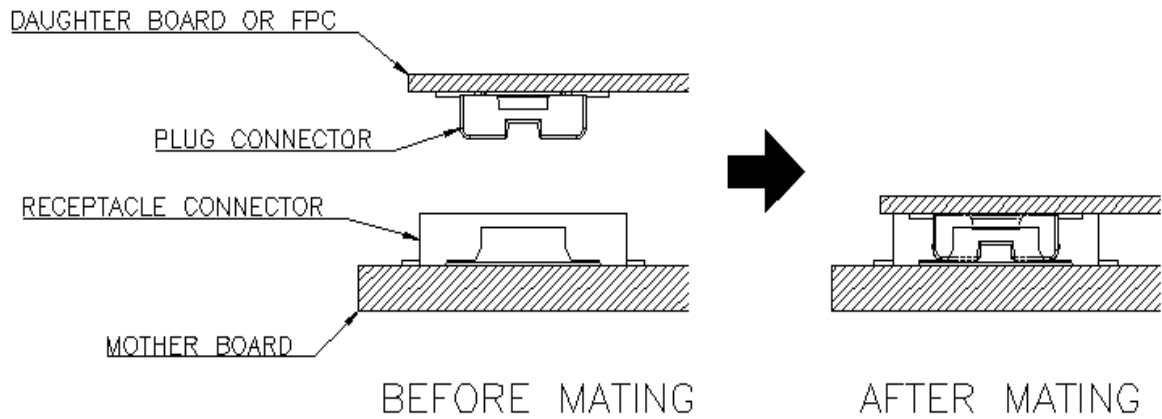



TITLE: 0.635mm Board To Board CONN

RELEASE DATE: 2017/07/04

REVISION: 0

ECN No: ECN-1801372

PAGE: 9 OF 8

## 8 PRODUCT QUALIFICATION AND TEST SEQUENCE

Test or Examination	Test Group											
	1	2	3	4	5	6	7	8	9	10	11	12
	Test Sequence											
Examination of Product	1、5	1、5	1、7	1、6	1、6	1、4	1、3		1、3	1、3		1、4
Low-signal Level Contact Resistance	2、7	2、6	2、10	2、9	2、9	2、5			4			2、5
Insulation Resistance			3、9	3、8	3、8							
Dielectric Withstanding Voltage			4、8	4、7	4、7							
Temperature rise											1	
Mating / Unmating Forces	3、6											
Durability	4											
Vibration(Random) / Vibration		3										
Shock (Mechanical)		4										
Heat Resistance				5								
Thermal Shock			5									
Humidity			6									
Temperature life					5							
Salt Spray						3						
Solder ability							2					
Terminal / Housing Retention Force								1				
Fitting Nail /Housing Retention Force								2				
Resistance to Soldering Heat									2			
Hand Soldering Temperature Resistance										2		
SO2 Gas												3
Sample Size	4	4	4	4	4	4	2	4	4	4	2	4